

DESCRIZIONE		SOSTITUISCERE		DATA	
OPTIONAL					
FUSE: 14A L250V 5x20					
Code Machine		denominazione		Codice	
re-examined	date/da/re	WIRING DIAGRAM		82129	
inspected by	05/09/08	Dishwashers		n°/file mod	
validated by	date/da/re	total BLOC	N° BLOC	next BLOC	
		3	2	-3	
82129					

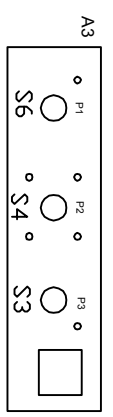
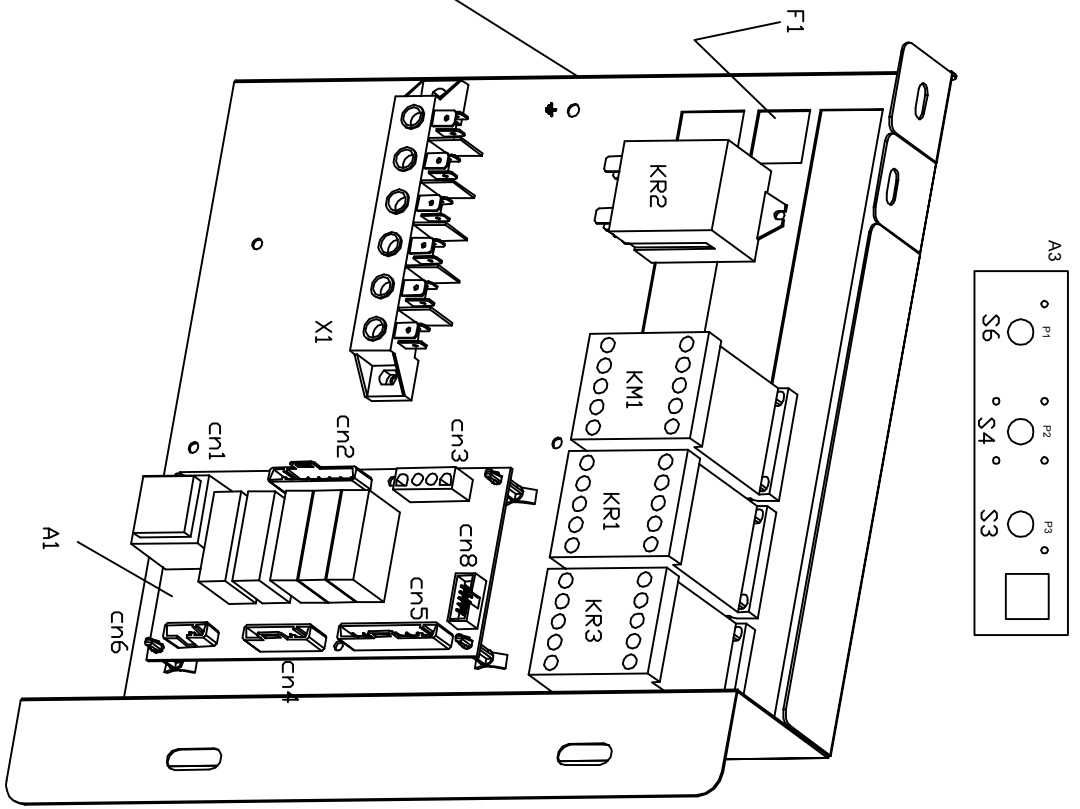
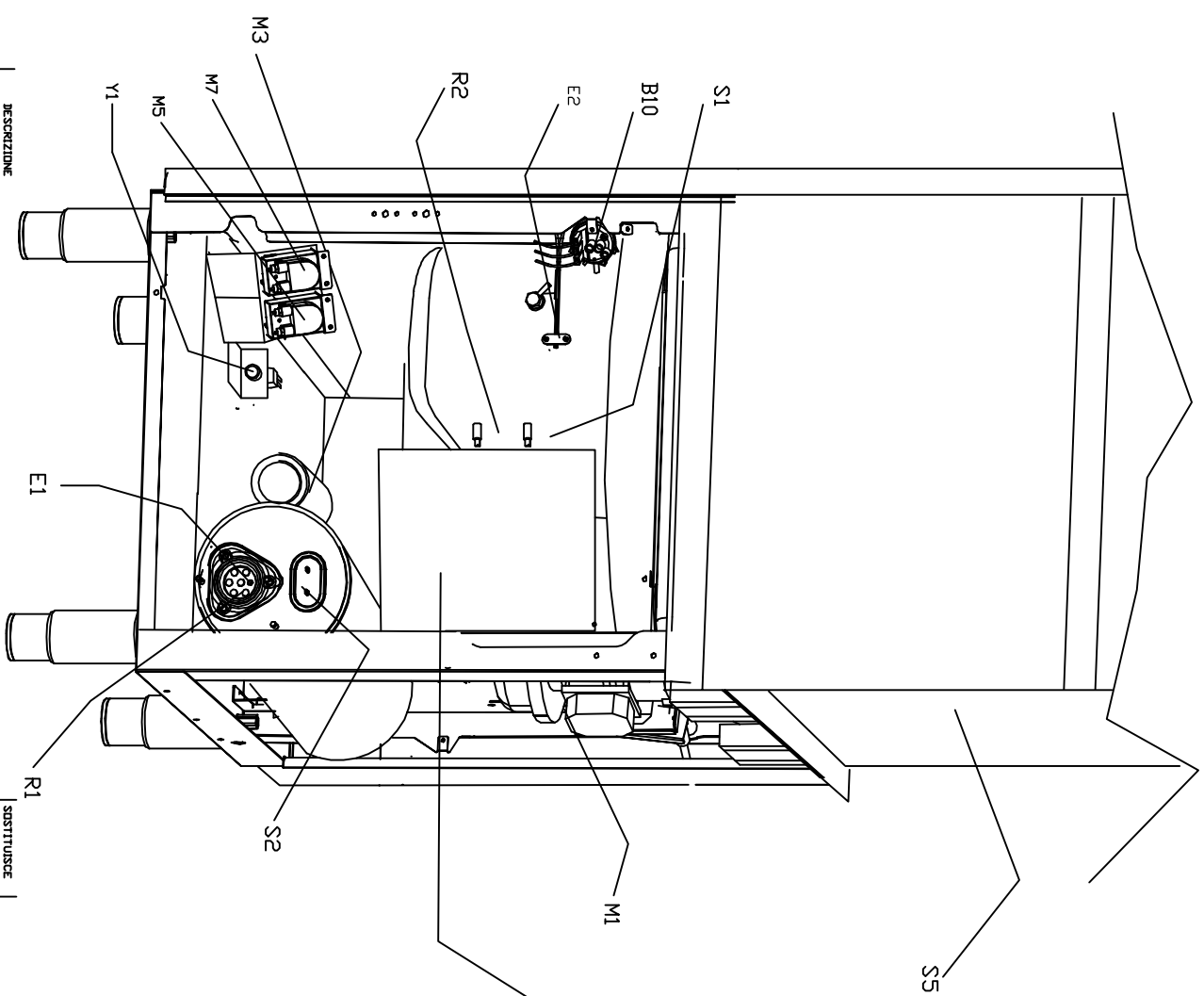

DESCRIZIONE

SOSTITUISCIE

DATA

Code Machine		denominazione		Codice	
re-examined	date/re/date	WIRING DIAGRAM		82129	
inspected by	date/date	Diswashers		n°/file	mod
validated by	date/date	total	next	82129L	-
		3	2		
			-3		

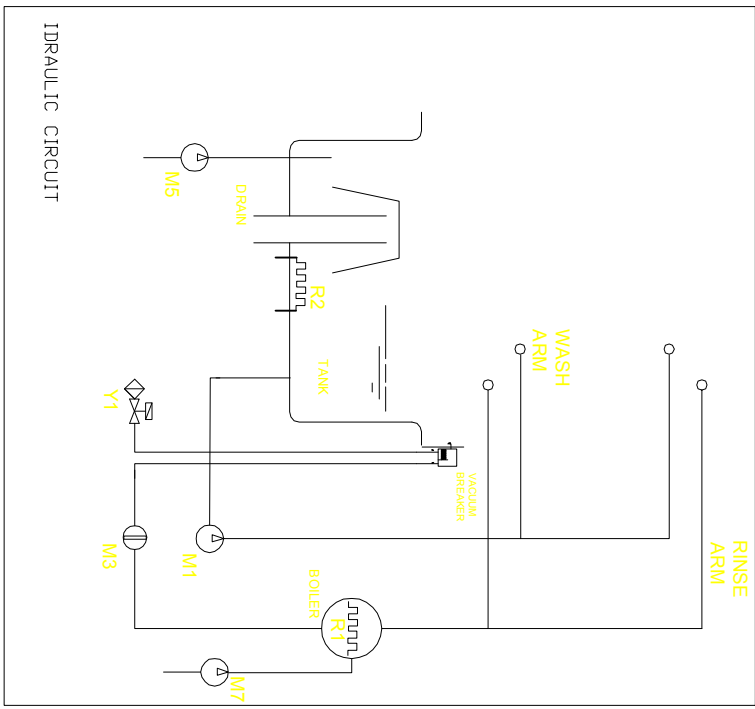

DESCRIZIONE

SOSTITUISCE

DATA

Code Machine	denominazione	Codice
re-examinated	date/date	
inspected by	date/date	n°/file
validated by	date/date	mod
WIRING DIAGRAM Dishwashers total bloc 4 n° bloc 4 next bloc --		821291